

Shop Notes

Design Software

*The most frequent question I'm asked whenever I post pictures of a piece of woodworking is :
"What software did you use to design that?"*

I suppose it's natural given the drawings that often accompany the articles. But the disappointing truth is that I don't use design or CAD software before I build. All of these drawings are after the fact creations in my favorite graphics application: Freehand. This Luddite approach surprises most who know me. Because my days are spent bathed in the glow of multiple monitors, it's assumed that I think that everything is best done on a computer. Nothing could be farther from the truth. Most every situation I encounter in the shop can be handled with a pen and a piece of graph paper-and usually faster. The finer details are settled during construction - measured against actual openings and the like.

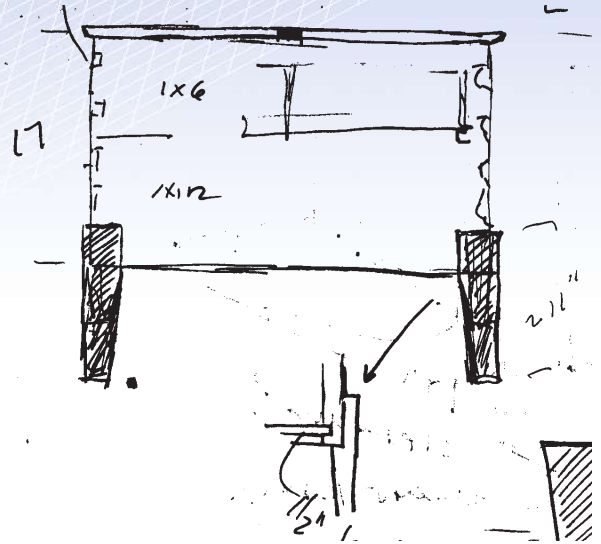

The photographs with this article show a simple chest I built for some friends at Christmas, and the single drawing that existed before I started.

Not much to it really. I started by making the legs. When those were fabricated I made a mock-up of the chest with corrugated cardboard and attached the legs with spring clamps. This let me verify the dimensions looked right from several angles. The box is a simple six-board trunk, dovetailed at the corners, bottom set in a groove, and a top with breadboard edging on three sides. All of the planks were edge-glued from narrower widths. After all, when was the last time you saw an 18 inch wide board?

And now, for the folks who've asked, a measured drawing

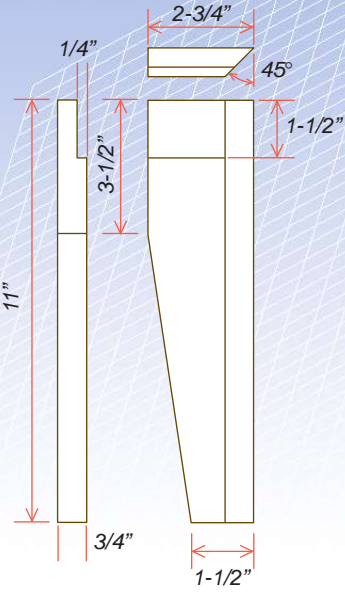

Dimensions for legs. Each leg consists of two mirror-image pieces glued together.



Assembled leg.

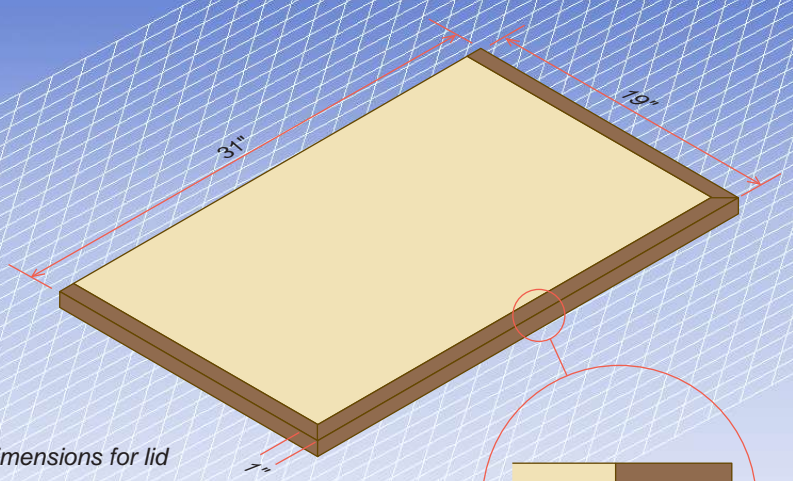

Dimensions for lid

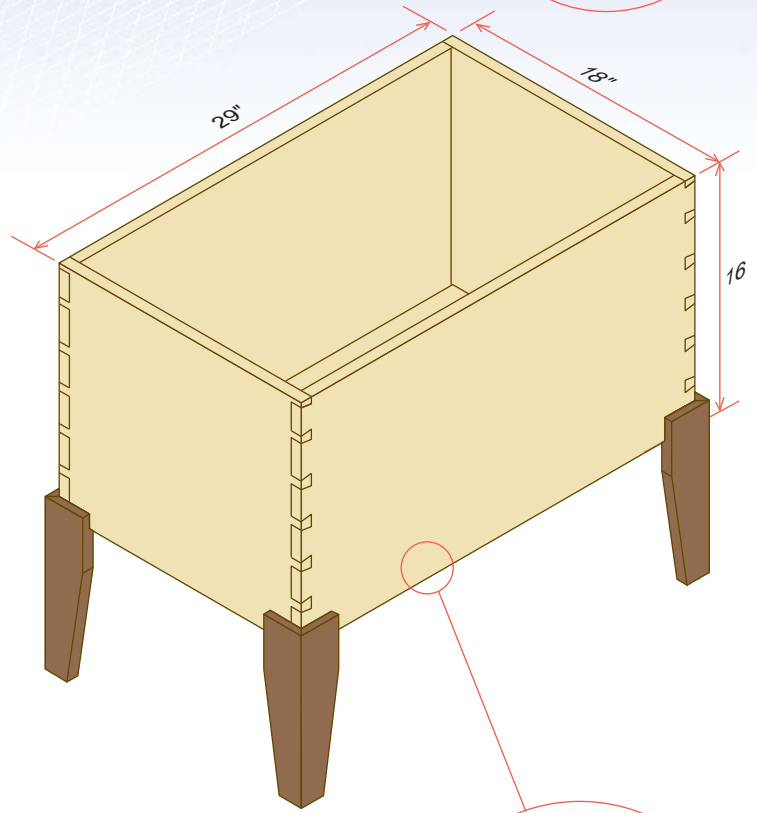
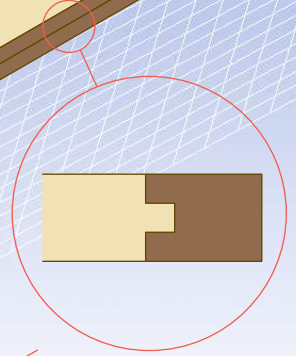

Dimensions for dovetail-joined box.

